

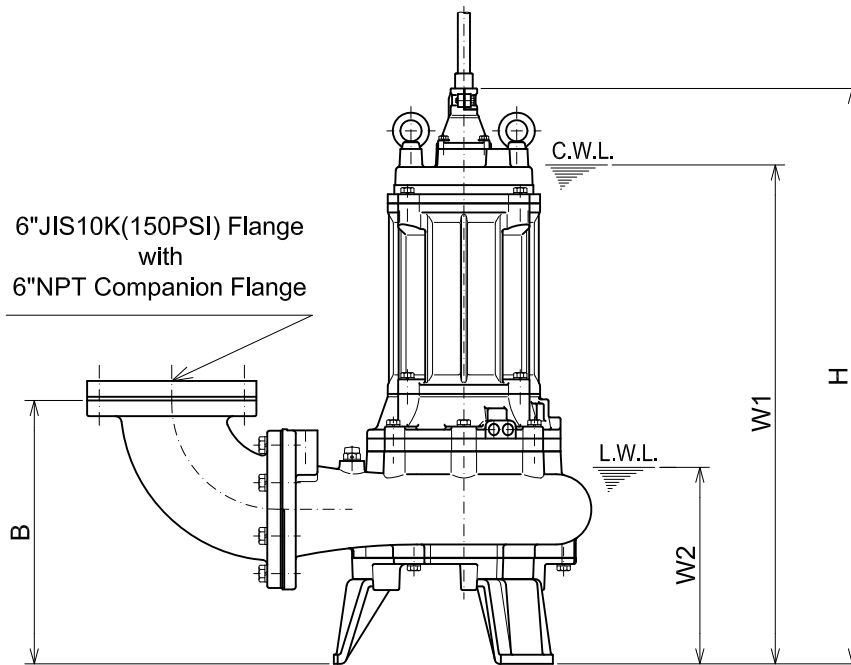

**B-SERIES
SEWAGE & WASTEWATER PUMPS**

DIMENSIONS

150B47.5H -63

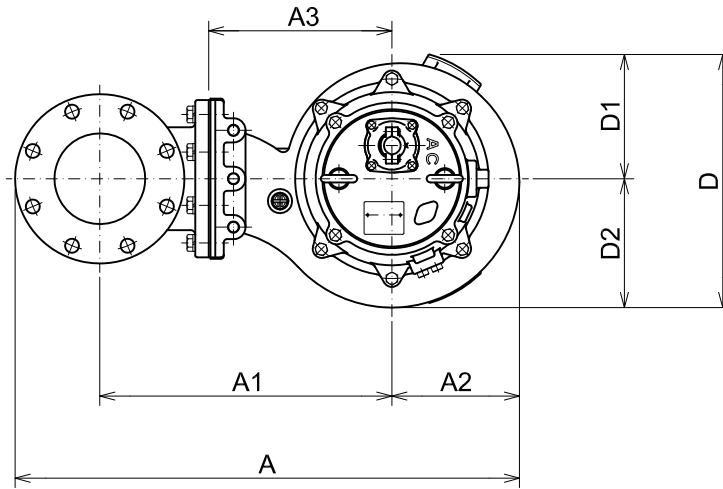

C.W.L. :Continuous running Water Level
L.W.L. :Lowest running Water Level

DIMENSIONS:USCS(Inch)

Model	HP	NOM. SIZE	Pump & Motor									C.W.L.	L.W.L.	Wt. (lbs.)
			A	A1	A2	A3	B	D	D1	D2	H			
150B47.5H -63	10	6"	32 13/16	19	8 5/16	11 13/16	17 3/16	16 7/16	8 1/16	8 3/8	37 1/2	32 1/2	12 3/4	463

*Excluding Cable.

DIMENSIONS:METRIC(mm)

Model	kW	NOM. SIZE	Pump & Motor									C.W.L.	L.W.L.	Wt. (kg)
			A	A1	A2	A3	B	D	D1	D2	H			
150B47.5H -63	7.5	150	834	483	211	300	436	418	205	213	952	825	325	210

TOS150B47.5H -63

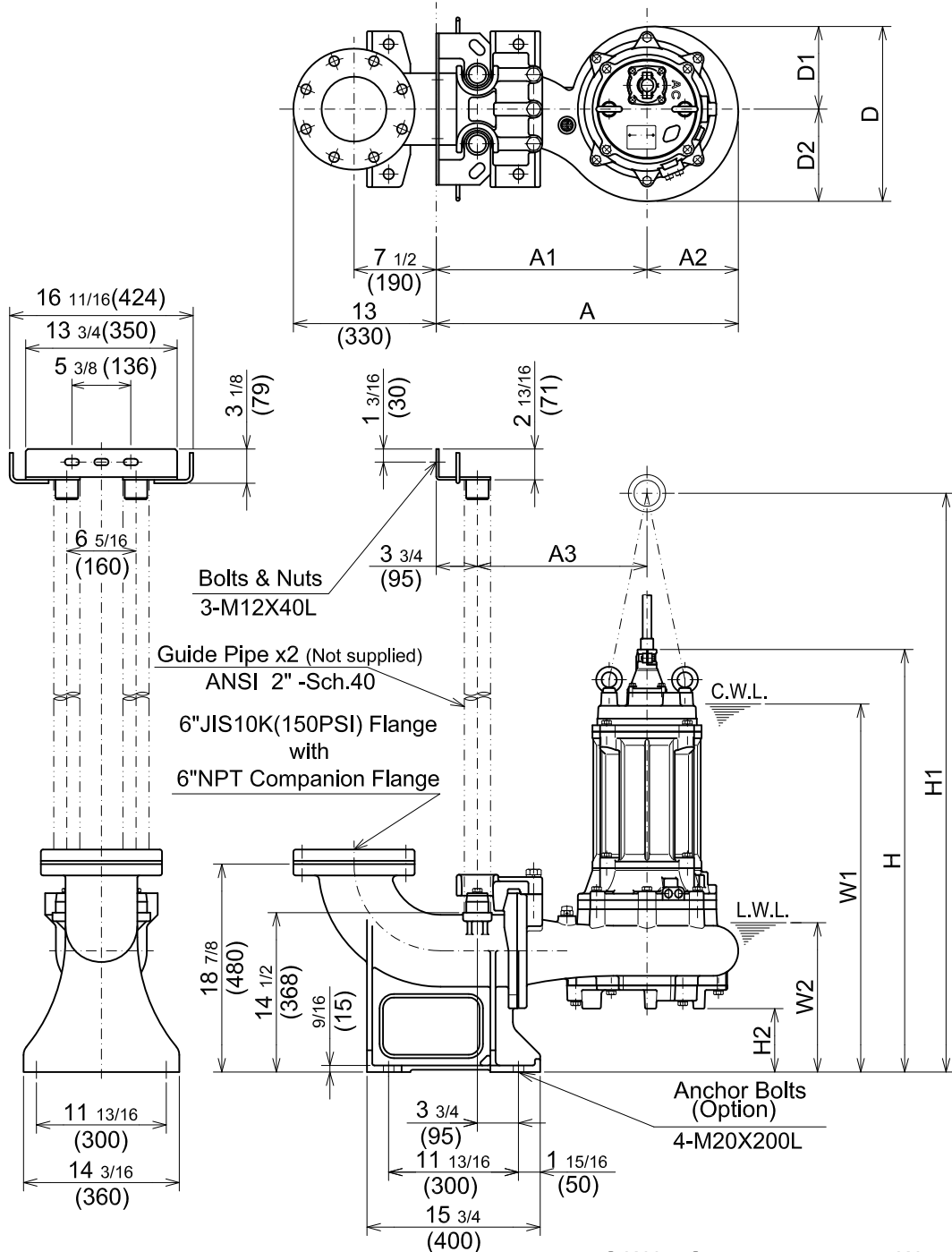

C.W.L. :Continuous running Water Level
L.W.L. :Lowest running Water Level

DIMENSIONS:USCS(Inch)

Model	HP	NOM. SIZE	Pump & Motor									C.W.L.	L.W.L.	Wt. (lbs.)	
			A	A1	A2	A3	D	D1	D2	H	H1				H2
TOS150B47.5H -63	10	6"	27 1/2	19 3/16	8 5/16	15 7/16	15 7/8	7 1/2	8 3/8	38 7/16	52 13/16	5 13/16	33 1/2	13 5/8	400

DIMENSIONS:METRIC(mm)

Model	kW	NOM. SIZE	Pump & Motor									C.W.L.	L.W.L.	Wt. (kg)	
			A	A1	A2	A3	D	D1	D2	H	H1				H2
TOS150B47.5H -63	7.5	150	698	487	211	392	404	191	213	976	1342	147	850	345	180



B-SERIES
SEWAGE & WASTEWATER PUMPS

PERFORMANCE
CURVE

MODEL	BORE	HP	KW	RPM	SOLIDS DIA.	LIQUID	SG.	VISCOSITY	TEMP.
(TOS)150B47.5H -63	6"/150mm	10	7.5	1748	2.76"/70mm	Water	1.0	1.123cSt.	60°F
PUMP TYPE	PHASE	VOLTAGE	AMPERAGE	HZ	STARTING METHOD	INS.CLASS			
Sewage&Wastewater	3	230/460/575	26.6/13.4/10.8	60	Direct On Line	F			
CURVE No.	DATE	PHASE	VOLTAGE	AMPERAGE	HZ	STARTING METHOD	INS.CLASS		
-	-	-	-	-	-	-	-		

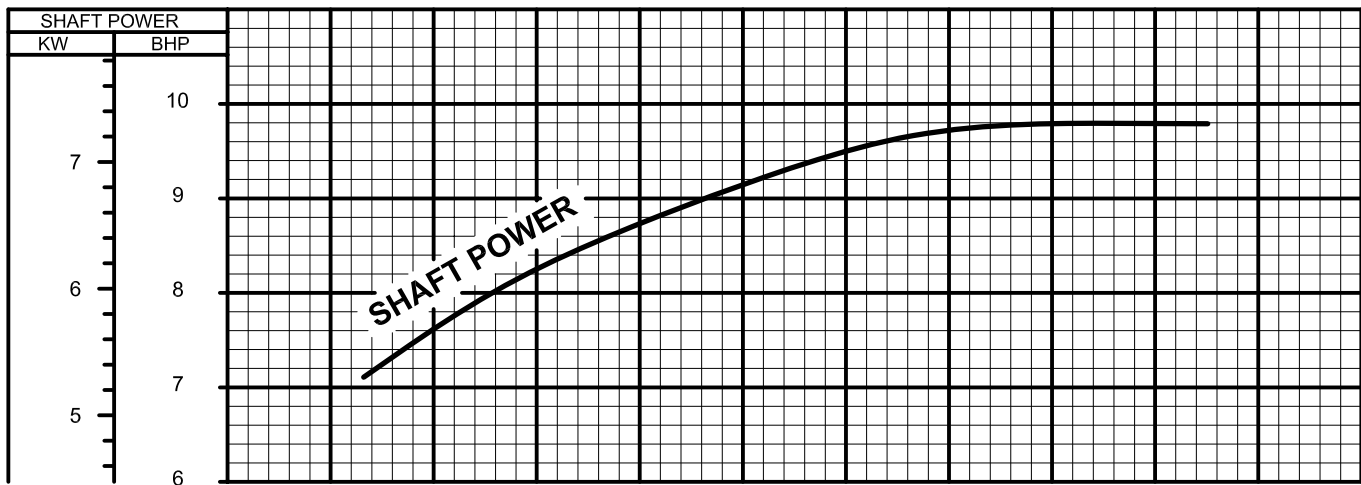
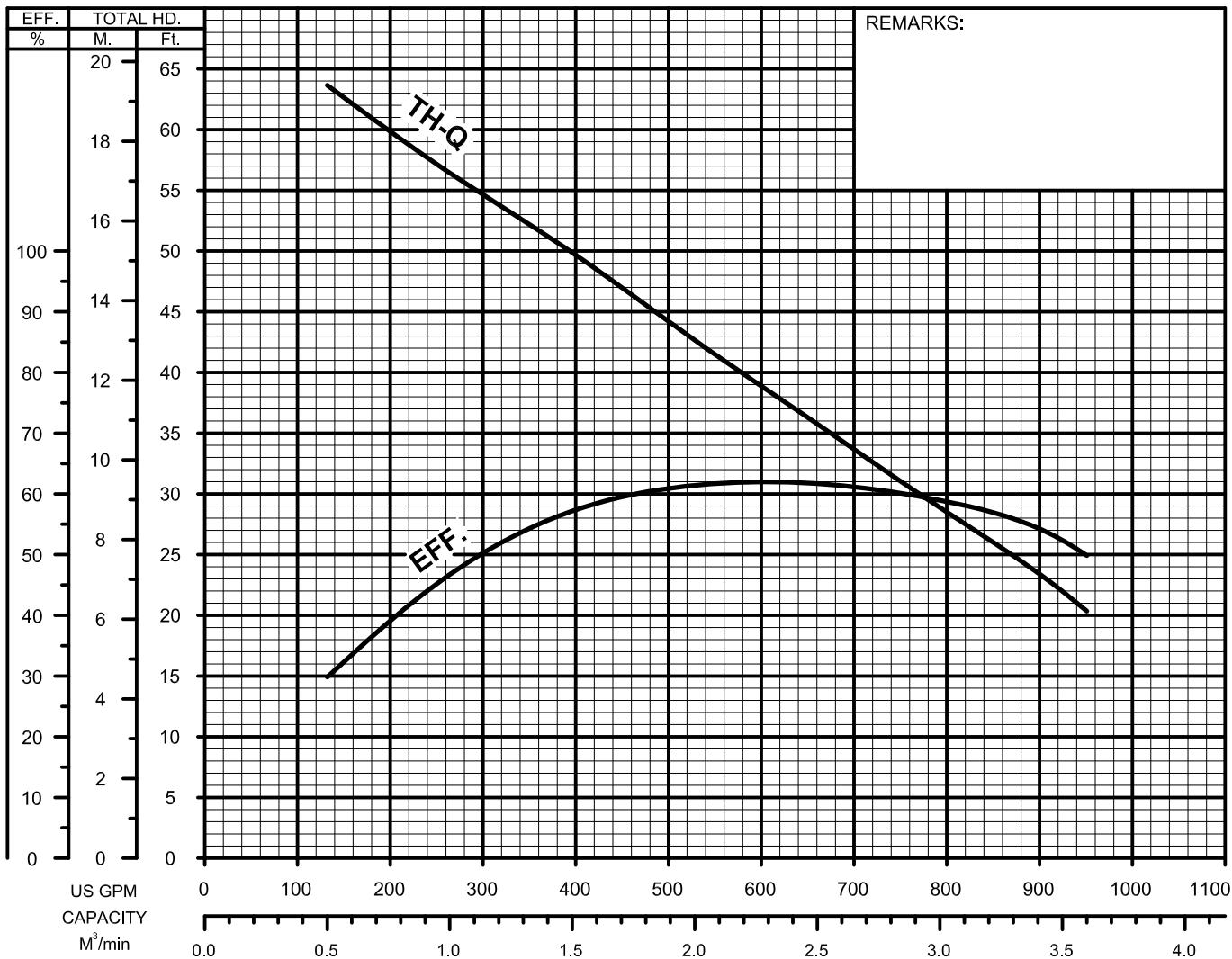

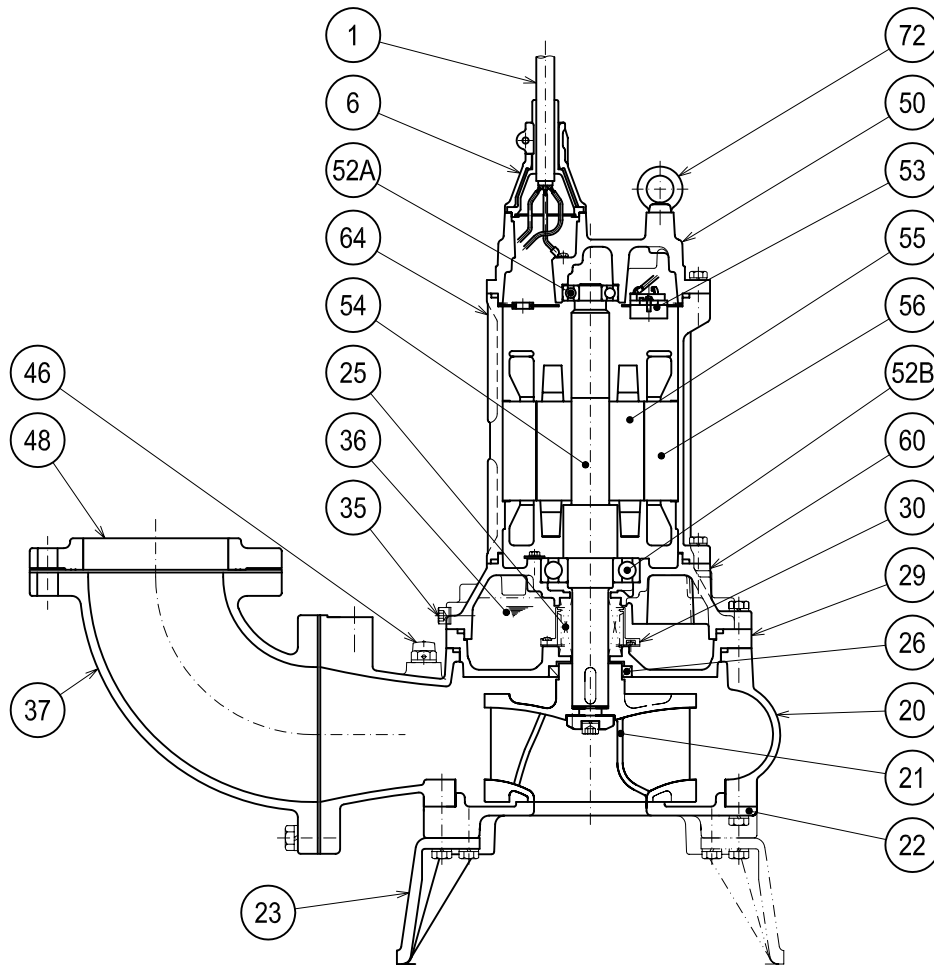
150B47.5H -63

PART#	DESCRIPTION	MAIN MATERIAL / NOTE	RELATED ASTM,AISI CODE	RELATED EN CODE	QTY
1	Power Cable	Chloroprene Sheath AWG 10/4-32ft			1
6	Stuffing Box	Cast Iron	A48M Class30B	EN 1561 GJL-200	1
20	Pump Casing	Cast Iron	A48M Class30B	EN 1561 GJL-200	1
21	Impeller	Cast Iron	A48M Class30B	EN 1561 GJL-200	1
22	Suction Cover	Cast Iron	A48M Class30B	EN 1561 GJL-200	1
23	Pump Stand	Cast Iron	A48M Class30B	EN 1561 GJL-200	3
25	Mechanical Seal	Silicon Carbide / H-40			1
26	Oil Seal	NBR / TC709212			1
29	Oil Casing	Cast Iron	A48M Class30B	EN 1561 GJL-200	1
30	Oil Lifter	PBT Resin W/GF40			1
35	Oil Plug	Stainless Steel	S 30400	1.4301	2
36	Lubricant	Turbine Oil ISO VG32 or SAE 10W-20			
37	Discharge Bend	Cast Iron	A48M Class30B	EN 1561 GJL-200	1
46	Air Release Valve	Nylon			1
48	Companion Flange	Cast Iron / NPT 6"	A48M Class30B	EN 1561 GJL-200	1
50	Motor Bracket	Cast Iron	A48M Class30B	EN 1561 GJL-200	1
52A	Upper Bearing	AC-#6306ZZC3			1
52B	Lower Bearing	#6310ZZC3			1
53	Motor Protector				1
54	Shaft	Stainless Steel	S 42000	1.4028	1
55	Rotor				1
56	Stator				1
60	Bearing Housing	Cast Iron	A48M Class30B	EN 1561 GJL-200	1
64	Motor Housing	Cast Iron	A48M Class30B	EN 1561 GJL-200	1
72	Lifting Lug Bolt	Steel	A283 Grade D	EN 10025 S275	2

PARTS LIST		SEWAGE & WASTEWATER PUMPS				5/23/2018
ITEM	PART No.	DESCRIPTION	QTY	SIZE	MATERIAL	NOTES
1	140-055-10	Hex.Bolt	4	M8x25	SUS304	
2	142-163-18	Spring Washer	4	M8	SUS304	
3	006-126-14	Stuffing Box	1	No.2	FC	included in ITEM#6 cable ass'y
4	070-107-18	Cable Clamp	1		FC	included in ITEM#6 cable ass'y
5	140-035-14	Hex.Bolt	2	M6x20	SUS304	included in ITEM#6 cable ass'y
6	001-938-25	Cabtyre Cable Set (32') 60Hz	1	2PNCT4Cx5.5mm2	KR-2	
7	008-143-13	Mould Cover	1	KR2-8	CR	included in ITEM#6 cable ass'y
8	009-276-19	Compression type Terminal	3	TMNB-5.5(Insulated)		included in ITEM#6 cable ass'y
9	143-085-21	Pan Screw (w/Spring Washer)	1	M4x6	SWRM	
10	009-130-10	Terminal	1	R-5.5-4	CU	included in ITEM#6 cable ass'y
11	140-098-15	Hex.Bolt	4	M12x35	SUS304	
12	142-165-10	Spring Washer	4	M12	SUS304	
13	050-000-23	Motor Bracket	1		FC	
14	072-107-14	Eye Bolt	2	M16	SS	can substitute 072-107-27 (SUS304)
15	142-399-15	Washer		d17xd29x0.1t	SUS304	
	142-400-10	Washer		d17xd29x0.3t	SUS304	
16	122-173-19	O-Ring	1	V-225(222.5xd6)	NBR	*
17	142-000-08	Wave Washer	1	6306B(d71xd59x4.0t)	SK5	
18	052-000-25	Bearing (w/O-ring)	1	AC-6306ZC3		
19	058-000-09	Lead Wire Protection Plate	1	d86xd224x1.6t	SPHC	
20	143-126-12	Pan Screw (w/Spring Washer/Plain Washer)	2	M4x12	SWRM	
21	053-456-12	Motor Protector 230V-60Hz	1	KA314-HLBL00	(H.C)	
	053-485-10	Motor Protector 460-575V-60Hz	1	KA314-HKXL00	(H.C)	
22	055-000-82	Rotor	1Set			
23	147-005-16	Impeller Key	1	12x8x40	SUS304	
24	056-C01-19	Stator 230V-60Hz	1Set			
	056-C02-10	Stator 460V-60Hz	1Set			
	056-C05-13	Stator 575V-60Hz	1Set			
25	064-000-12	Motor Frame	1		FC	
26	140-100-11	Hex.Bolt	4	M12x45	SUS304	
27	142-165-10	Spring Washer	4	M12	SUS304	
28	122-173-19	O-Ring	1	V-225(222.5xd6)	NBR	*
29	140-000-06	Hex.Bolt (w/Spring Washer/Plain Washer)	3	M6x12	SWCH	
30	052-113-11	Bearing	1	6310ZC3		
31	140-099-16	Hex.Bolt	2	M12x40	SUS304	
32	142-165-10	Spring Washer	2	M12	SUS304	
33	140-104-15	Hex.Bolt	4	M12x65	SUS304	
34	142-165-10	Spring Washer	4	M12	SUS304	
35	060-000-52	Bearing Housing	1		FC	

PARTS LIST		SEWAGE & WASTEWATER PUMPS				5/23/2018
ITEM	PART No.	DESCRIPTION	QTY	SIZE	MATERIAL	NOTES
36	035-113-18	Oil Plug	2	M12x14	SUS304	
37	121-247-12	Packing	2	d12.3xd18x2t	PE	*
38	025-000-61	Mechanical Seal	1	H-40X(E)	SiC	interchangable with OLD part# 025-000-38
39	143-070-23	Pan Screw	2	M5x6	SWRM	
40	030-141-10	Oil Lifter	1	H-40(T)	Resin	
41	143-070-10	Pan Screw	3	M5x6	SWRM	
42	030-149-18	Seal Stopper	1	H-40/45	SPCC	
43	122-159-19	O-Ring	1	G-280(279.3xd5.7)	NBR	*
44	029-000-24	Oil Casing	1	150B47.5H-53/63	FC	
45	026-117-14	Oil Seal	1	TC-709212	NBR	
46	021-004-42	Impeller (50Hz) OPTION	1	150B47.5H-53	FC	50Hz OPTION
46	021-004-43	Impeller (60Hz)	1	150B47.5H-63	FC	
47	144-530-16	Hex. Socket Cap Screw	2	M6x15	SUS304	
48	142-202-10	Impeller Fixing Washer	1	d13xd50x15t	SUS304	
49	142-000-22	Spring Washer	1	M12(CP)	SUS304	
50	140-304-17	Hex.Socket Cap Bolt	1	M12x45	SUS304	
51	046-107-13	Air Release Valve	1	PT-1/2	Nylon	
52	122-159-19	O-Ring	1	G-280(279.3xd5.7)	NBR	*
53	020-647-10	Pump Casing	1	150-7.5-4BH	FC	
54	120-102-11	Packing (S.Cover)		d301xd328x0.3t	PE	
55	022-000-73	Suction Cover	1	150B47.5H-53/63	FC	
56	023-288-18	Pump Stand	3	55/110-CE2	FC	
57	142-165-10	Spring Washer	3	M12	SUS304	
58	140-097-14	Hex.Bolt	3	M12x30	SUS304	
59	142-165-10	Spring Washer	3	M12	SUS304	
60	140-097-14	Hex.Bolt	3	M12x30	SUS304	
61	142-165-10	Spring Washer	3	M12	SUS304	
62	140-105-16	Hex.Bolt	3	M12x70	SUS304	
63	121-165-28	Packing	1	JIS5Kx150mm	NR	
64	037-119-10	Discharge Bend	1	150x150mm	FC	
65	142-166-11	Spring Washer	8	M16	SUS304	
66	140-127-14	Hex.Bolt	8	M16x55	SUS304	
	173-001-16	Packing O-Ring Set	1Set	(Marked by *)		
16	122-173-19	O-Ring (M.Bracket/M.Frame)	1	V-225(222.5xd6)	NBR	*
28	122-173-19	O-Ring (M.Frame/Brg.Housing)	1	V-225(222.5xd6)	NBR	*
37	121-247-12	Packing (Oil Plug)	2	d12.3xd18x2t	PE	*
43	122-159-19	O-Ring (Brg.Housing/O.Casing)	1	G-280(279.3xd5.7)	NBR	*
52	122-159-19	O-Ring (O.Casing/P.Casing)	1	G-280(279.3xd5.7)	NBR	*
		Lubricant		Turbine Oil VG32 3,500ml		

PARTS LIST		SEWAGE & WASTEWATER PUMPS			5/23/2018	
ITEM	PART No.	DESCRIPTION	QTY	SIZE	MATERIAL	NOTES

EXPLODED VIEW

150B47.5H-53/63

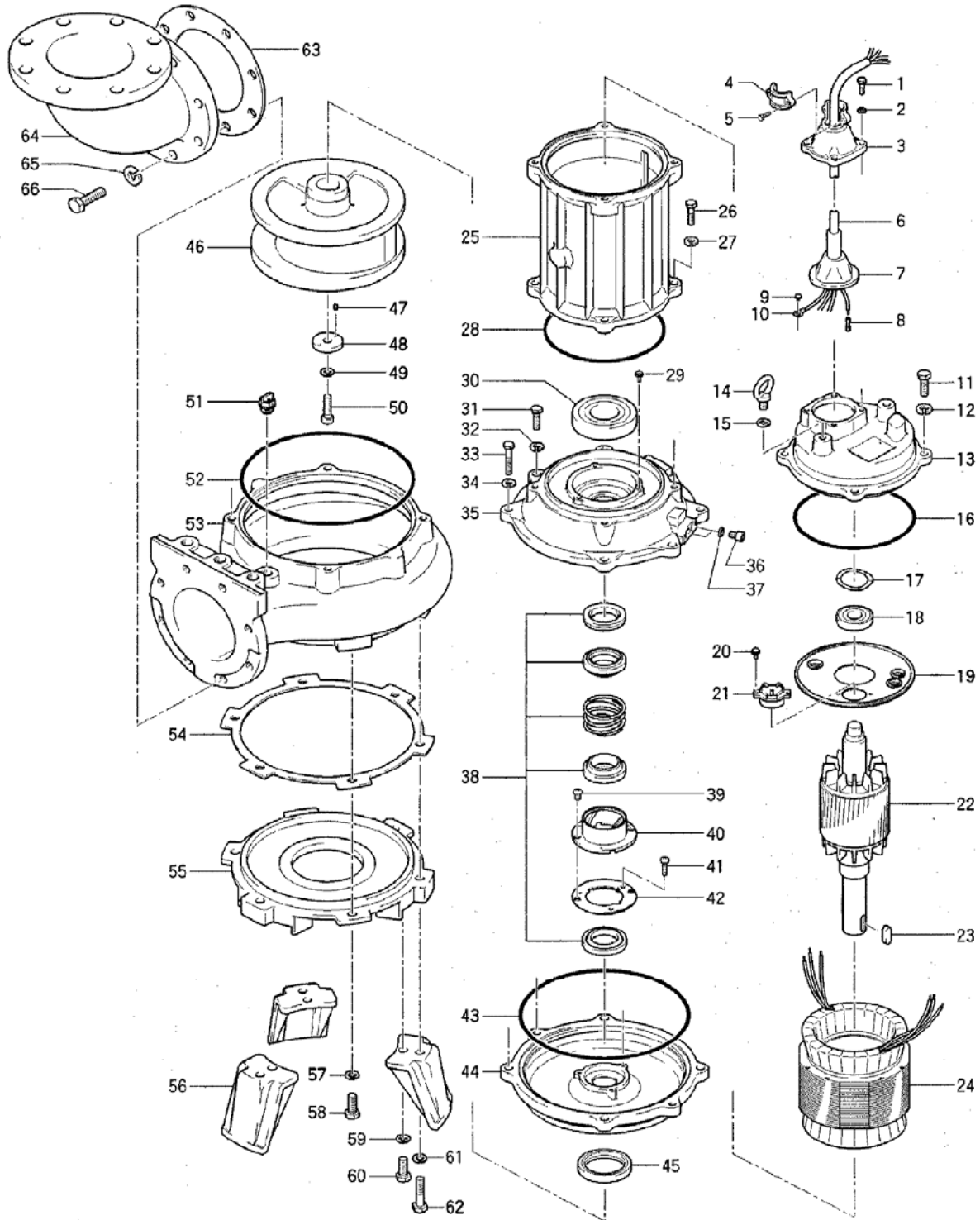

管理no. C-00744-1